

iA (intelligent Auto) H.265 Network Camera

Panasonic WV-S1531LN captures the highest quality images automatically even in very challenging and fast-changing surveillance environments. Intelligent Auto (iA) monitors scene dynamics and motion to adjust key camera settings automatically in real-time reducing distortion such as motion blur on moving objects. New industry-leading 144dB dynamic range delivers balanced scene exposure in dynamic and extreme-backlit lighting environments. In addition, color night vision provides outstanding low-light performance with accurate color rendition and saturation from i-Pro's 1/3" sensor, rivaling the performance of costlier 1/2" sensor cameras in the market. Adopting H.265 Smart Coding technology, intelligently reduces bandwidth efficiency of up to an average 75 percent over H.264 for longer recording and less storage. Cameras out-of-the-box, support full data encryption streaming and is compliant to FIPS 140-2 Level 1 standards to keep your video secured.

Extreme image quality for evidence capturing under challenging conditions.

- Auto Shutter speed control for fast moving vehicles
- Sharp and clear image of a walking person day & night
- Outstanding low light performance in true color with low noise for night time applications
- Super Dynamic 144dB for backlit situation and shadows on the streets at night

Extreme H.265 compression with new Smart Coding

- Longer recording, less storage compared to any H.264 based compression techniques
- New self-learning ROI* encoding (Auto VIQS) dynamically detect motion areas to keep vehicles and human in good picture quality while lowering your bandwidth
- New "Smart Facial Coding" adds more bandwidth reduction for ID camera applications mainly capturing faces

* Region of Interest

Extreme Data Security

- Full encryption SD card edge recording to keep your data safe
- FIPS 140-2 Level 1 compliant
- Full end-to-end system encryption with supported VMS and devices to protect from IP snooping/spoofing and detect data alteration

Key Features

- Full HD 1080p 60fps
- iA (intelligent Auto)
- Extreme Super Dynamic 144dB
- Color night vision (0.0008 to 0.012 lx)
- H.265 Smart Coding
- FIPS 140-2 Level 1 compliant
- Clear Sight Coating

Applications

- Public safety (City / Highway tolls / Parking gates)
- Transportation (Airport / Train / Subway)
- Retail / Bank / Logistics / Education / Hospital / Building



Specifications

Camera	Image Sensor	Approx. 1/3 type MOS image sensor
	Minimum Illumination	Color : 0.012 lx, BW : 0.006 lx (F1.6, Maximum shutter : Max. 1/30s, AGC : 11) BW : 0 lx (F1.6, Maximum shutter : Off(1/30 s), AGC : 11, when the IR LED is lit) Color : 0.0008 lx, BW : 0.0004 lx (F1.6, Maximum shutter : Max. 16/30s, AGC : 11) *1
	White Balance	AWC (2,000 - 10,000 K), ATW1 (2,700 - 6,000 K), ATW2 (2,000 - 6,000 K)
	Shutter Speed	Off(1/30) to 1/10000 *1/30 Fix to 2/100 Fix is available during 30 fps mode only. *2/120 Fix is available during 60 fps mode only.
	Intelligent Auto	On / Off
	Super Dynamic ²	On / Off, the level can be set in the range of 0 to 31.
	Dynamic Range	144 dB (Super Dynamic : On)
	Adaptive Black Stretch	The level can be set in the range of 0 to 255.
	Black light compensation / High light compensation	BLC (Black light compensation) / HLC (High light compensation) / Off (Only when Super dynamic and Intelligent Auto : Off)
	Fog compensation	On / Off (Only when Intelligent Auto : Off)
	Maximum gain (AGC)	The level can be set in the range of 0 to 11.
	Day/Night (ICR)	Off / On / Auto1 (Normal) / Auto2 (IR Light) / Auto3 (SCC)
	IR LED	Off / Auto (High / Mid / Low) irradiation distance : 40 m (131 feet)
	Digital Noise Reduction	The level can be set in the range of 0 to 255.
	Video Motion Detection	On / Off, 4 areas available
	Image Stabilizer	On / Off (available only in the 30 fps mode)
	Privacy Zone	On / Off (up to 8 zones available)
	Image rotation ³	0° / 90° / 180° / 270°
	Camera Title (OSD)	On / Off Up to 20 characters (alphanumeric characters, marks)
	Focus Adjustment	Auto back focus / Manual
Lens	Focal length	2.8 - 10 mm (1/8 inches - 13/32 inches)
	Zoom ratio	3.6 x (Motorized zoom / Motorized focus)
	Angular Field of View	[16 : 9 mode] Horizontal : 31° (TELE) - 112° (WIDE) Vertical : 17° (TELE) - 60° (WIDE) [4 : 3 mode] Horizontal : 26° (TELE) - 91° (WIDE) Vertical : 19° (TELE) - 67° (WIDE)
	Maximum Aperture Ratio	1 : 1.6 (WIDE) - 1 : 3.4 (TELE)
	Focusing Range	0.3 m (11-13/16 inches) - ∞
Adjusting Angle	Ceiling mounting	Horizontal : ±180° (PAN rotation part) Vertical : 0° to 100° (TILT rotation part) Yaw : -190° to +100° (YAW rotation part)
	Wall mounting	Horizontal : ±100° (TILT rotation part)* Vertical : ±100° (TILT rotation part)* Yaw : -190° to +100° (YAW rotation part) * You can change between horizontal and vertical angles by adjusting the PAN rotation part.
	Camera Control	Brightness, AUX On / Off
	Audio	Mic (Line) Input : On / Off Volume adjustment : Low / Middle / High Audio Output : On / Off Volume adjustment : Low / Middle / High
Browser GUI	GUI / Setup Menu Language	English, Italian, French, German, Spanish, Portuguese, Russian, Chinese, Japanese
	Network IF	10Base-T / 100Base-TX, RJ45 connector
Network	Image Resolution	*2 mega pixel [16 : 9] (30/60 fps) 1,920 x 1,080 / 1,280 x 720 / 640 x 360 / 320 x 180 *3 mega pixel [4 : 3] (30 fps) 2,048 x 1,536 ¹ / 1,280 x 960 / 800 x 600 / 640 x 480 / 400 x 300 / 320 x 240 ¹ Used by super resolution techniques
	H.265/ ⁴ H.264	Constant bit rate / Variable bit rate / Frame rate / Best effort
	Transmission Type	Unicast / Multicast
	JPEG	Image Quality 10 steps

Network	Smart Coding	Smart Facial Coding : On (Smart Facial Coding*) / On (Auto VIQS) / Off *Smart Facial Coding is only available with Stream(1). GOP (Group of pictures) : On (Advanced)* / On (Low) / On (Mid) / Off *On(Advanced) is only available with H.265.	
	Audio Compression	G.726 (ADPCM) : 32 kbps / 16 kbps, G.711 : 64 kbps, AAC-LC ⁵ : 64 kbps / 96 kbps / 128 kbps	
	Audio transmission mode	Off / Mic (Line) input / Audio output / Interactive (Half duplex) / Interactive (Full duplex)	
	Supported Protocol	IPv6 : TCP/IP, UDP/IP, HTTP, HTTPS, RTP, FTP, SMTP, DNS, NTP, SNMP, DHCPv6, MLD, ICMP, ARP, DiffServ IPv4 : TCP/IP, UDP/IP, HTTP, HTTPS, RTSP, RTP, RTP/RTCP, FTP, SMTP, DHCP, DNS, DDNS, NTP, SNMP, UPnP, IGMP, ICMP, ARP, DiffServ	
	No. of Simultaneous Users	Up to 14 users (Depends on network conditions)	
	SDXC/SDHC/SD Memory Card (Option)	H.265 / H.264 recording : Manual REC / Alarm REC (Pre/Post) / Schedule REC / Backup upon network failure JPEG recording : Manual REC / Alarm REC (Pre/Post) / Backup upon network failure Compatible SD (SDHC/SDXC) card : Panasonic 2 GB, 4 GB ¹ , 8 GB ¹ , 16 GB ¹ , 32 GB ¹ , 64 GB ¹ , 128 GB ¹ model ¹ SDHC card, ² SDXC card (except miniSD card and microSD card)	
	Mobile Terminal Compatibility	iPad, iPhone, Android™ mobile terminals	
	Alarm	Alarm Source	3 terminals input, VMD, Command alarm, Audio detection alarm
		Alarm Actions	SDXC/SDHC/SD memory recording, E-mail notification, HTTP alarm notification Indication on browser, FTP image transfer, Panasonic protocol output
	Input/ Output	Monitor Output (for adjustment)	VBS : 1.0 V [p-p] / 75 Ω, composite, Pin jack An NTSC or PAL signal can be outputted from camera
Microphone/Line Input		ø3.5 mm stereo mini jack (Applicable microphone : Plug-in power type) Supply voltage : 2.5 V ±0.5 V	
Audio Output		ø3.5 mm stereo mini jack (monaural output) Output impedance : Approx. 600 Ω (unbalanced)	
External I/O Terminals		ALARM IN 1 (DAY/NIGHT IN, Auto time adjustment) (x1), ALARM IN 2 (ALARM OUT) (x1), ALARM IN 3 (AUX OUT) (x1)	
General	Power Source and Power Consumption	DC power supply : DC12 V / 750 mA / Approx. 9.0 W PoE (IEEE802.3af compliant) Device : DC48 V / 195 mA / Approx. 9.4 W (Class 0 device)	
	Ambient Operating Temperature	-40 °C to +60 °C (-40 °F to 140 °F)	
	Ambient Operating Humidity	10 to 100 % (no condensation)	
	Water and Dust Resistance	IP66, IEC60529 measuring standard compatible, Type 4X(UL50), NEMA 4X compliant	
	Shock Resistance	Compliant with IK10 (IEC 62262)	
	Dimensions	95 mm (W) x 99 mm (H) x 337 mm (L) (3-3/4 inches (W) x 3-57/64 inches (H) x 1ft 1-17/64 inches (L))	
	Mass (approx.)	Approx. 1.6 kg (3.53 lbs)	
	Finish	Main body : Aluminum die cast, light gray Front cover section clear part : Clear polycarbonate resin (clear sight coating)	

*1 Converted value

*2 Super Dynamic function is automatically set off on 60 fps mode.

*3 When "3 mega pixel [4 : 3](30fps mode)" is selected for "Image capture mode", "90 °" and "270 °" cannot be selected.

*4 Transmission for 4 streams can be individually set.

*5 Only use AAC-LC (Advanced Audio Coding - Low Complexity) when recording audio on an SD memory card.

Appearance

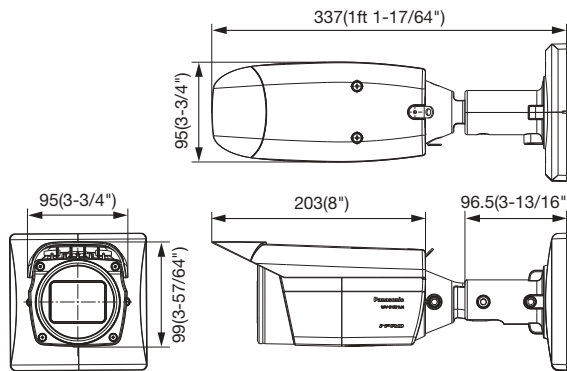

Unit : mm (inches)

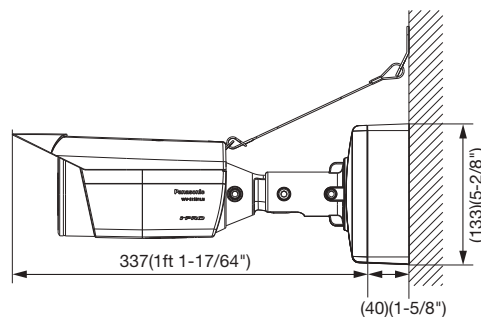

Trademarks and registered trademarks

- iPad and iPhone are registered trademarks of Apple Inc.
- Android is a trademark of Google Inc.
- ONVIF and the ONVIF logo are trademarks of ONVIF Inc.
- All other trademarks identified herein are the property of their respective owners.

• Masses and dimensions are approximate. • Specifications are subject to change without notice.

Important

- Safety Precaution : Carefully read the Important Information, Installation Guide and operating instructions before using this product.
- Panasonic cannot be responsible for the performance of the network and/or other manufacturers' products used on the network.

DISTRIBUTED BY :

Panasonic

<http://security.panasonic.com>

<http://www.facebook.com/PanasonicNetworkCamera>

(2A-181AA)